

A Nest-Box Plan for Western and Mountain Bluebirds

This is a fairly easy box to build. The large roof provides extra protection from rain and predators.

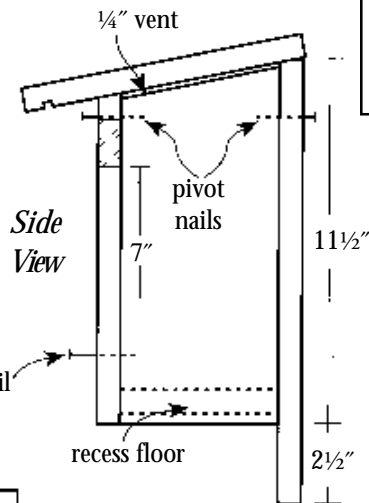
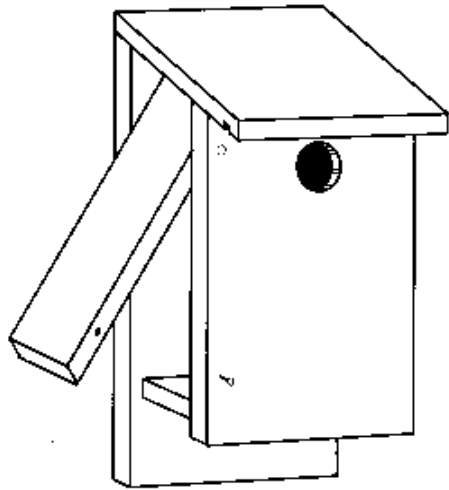

Materials List

- Cut from wood $\frac{3}{4}$ " thick:
- Top (w x h) 9" x 9"
 - Front 6½" x 10½"
 - Back 6½" x 14"
 - Sides (2) 5" x 11¼"
 - Bottom 5" x 5"

Hole diameter:

- 1½" for Western Bluebirds
- 1⅞" for Mountain Bluebirds

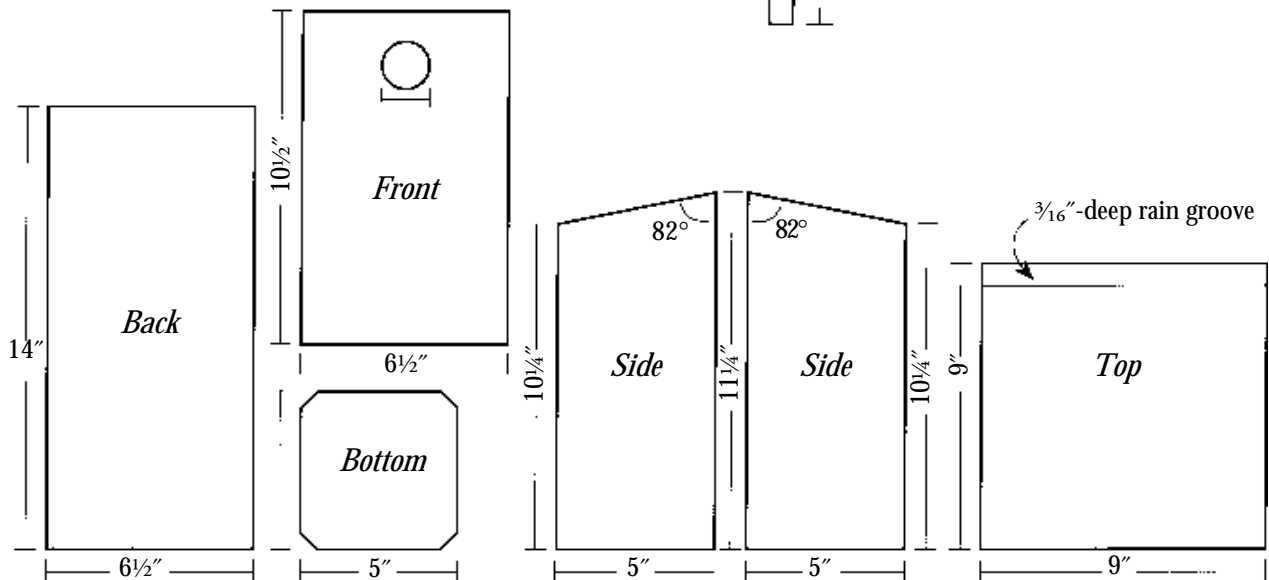

Printed with permission from *Bluebirds Forever* (Toops 1994)

Plans available from:

Hubert Prescott Western Bluebird Recovery Project
 c/o Patricia Johnston
 7717 SW 50th Avenue
 Portland, OR 97219
 (Include \$1.00 for postage and handling.)